

TO SLIGHTLY CORRECT THE AXIALITY AND DIAMETER OF THE HOLES.
 IT CAN WORK AUTOMATICALLY AND MANUALLY.

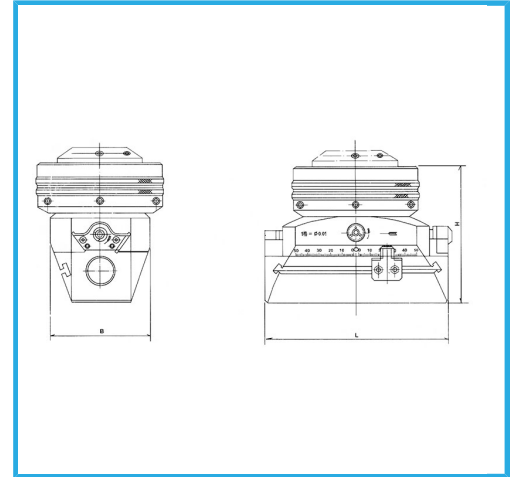

Max facing and boring \varnothing	150 mm
Max stroke of slide	± 15 mm
Fine feed per graduation	0,005 mm
Manual feed per revolution	2 mm
Self acting feed per revolution	0,02-0,04-0,06 0,08-0,10-0,12 mm
\varnothing of tool post holes in head	18 mm
Max \varnothing of head	90 mm
Height of head without shank - (H)	87,5 mm
Weight of head without shank	2,9 kg
Length of sliding block	75 (L) mm
Width of sliding block	70 (B) mm
Collets hole	4 - 8 - 12 \varnothing mm
Accessories	1 - 2 - 6
Extension hole for tool holder	$\varnothing 6$ mm
Shank	ISO40 - DIN2080
Gross weight	8,45 kg
EAN Code	8012667002909

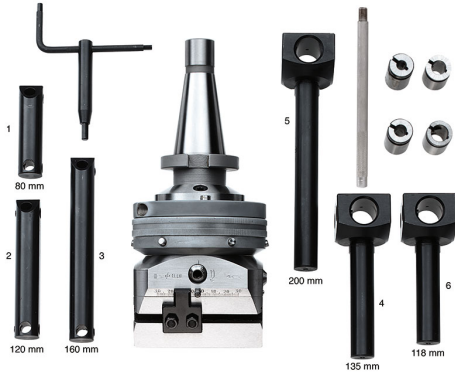

Box

40 Cr



Grounded